

NORDICTECH
WEBINARS



Understanding DECT NR+:

The first non-cellular

5G standard

Today's hosts

Heidi Sollie



Product Marketing Engineer



Lauri Piikivi



Technical Product Manager DECT NR+



Practicalities

- Duration: about 45 minutes
- Questions are encouraged!
 - Please type questions in the top of the right sidebar
 - All questions are anonymous
 - Try to keep them relevant to the topic
 - We will answer towards the end
- The chat is not anonymous, and do not use for questions
- Go to DevZone if you have more questions
- A recording of the webinar will be available together with the presentation at webinars.nordicsemi.com

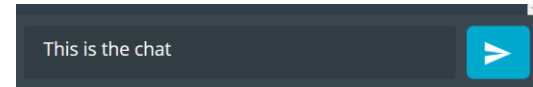
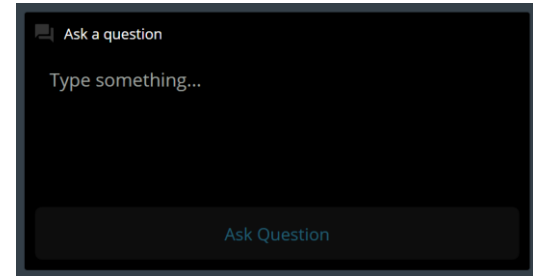

Agenda

- NR+: What is it and why should I care?
- Targeted applications and benefits
- NR+: How?
 - Upper layers, no physical stuff
- Status of the standard
- Status of the Implementation
- Q&A





The What

NR+, aka DECT-2020 NR

Why DECT NR+

- Opportunity to use existing spectrum allocation
- Utilizing existing cellular technology
- New radio standard



Targeted applications

Made for massive IoT networks and low latency communications

1. Massive IoT

- Networks of thousands of nodes
- **Use case:** Smart energy, smart city applications

2. Low latency communications

- Latency 1 ms
- **Use case:** Speech and audio, automation control

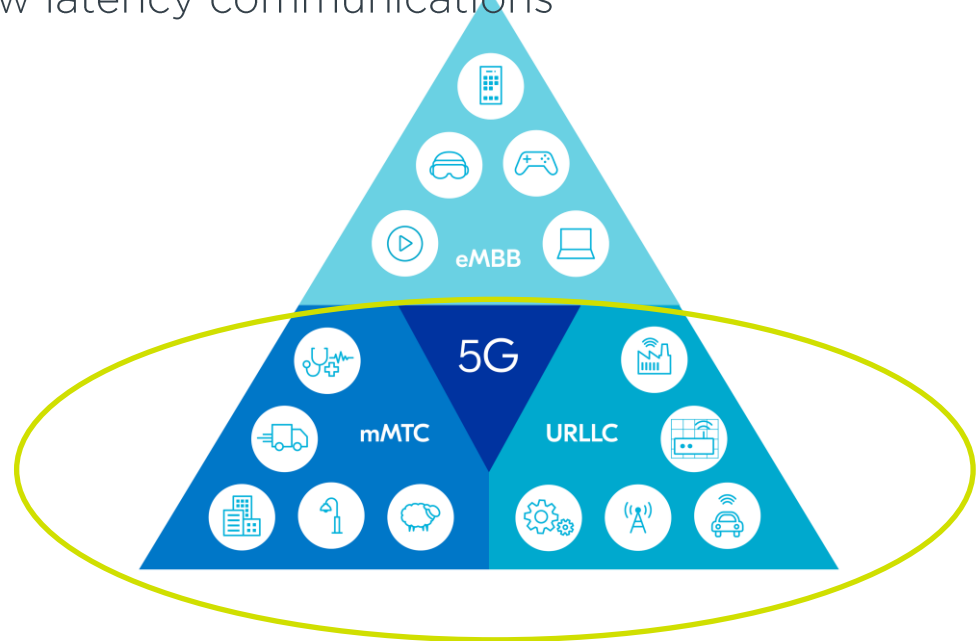

DECT NR+

Made for massive IoT networks and low latency communications

1. Massive IoT

- Networks of thousands of nodes
- **Use case:** Smart energy, smart city applications

2. Low latency communications

- Latency 1 ms
- **Use case:** Speech and audio, automation control

The benefits of NR+

Speed and latency



- **Speed:** 1 to 3.4 Mbps on HW, standard up to gigabits
- **Latency:** 1 ms on star, 10ms per hop minimum for mesh

Low-power



- Long sleep times for devices are possible

Mesh network



- Self healing
- Self load-balancing

Frequency spectrum



- Minimal cost of ownership
- No subscription costs
- Global spectrum 1900MHz, minimal regional variation
- Avoid congested 2.4GHz



The How

Diving into the protocol layers

Vocabulary

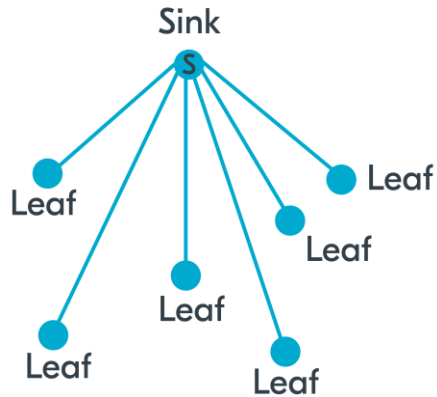

Star

Synonyms

1. Sink = Gateway / Border Router
2. FT = Relay Node / Router Node / Parent Node
3. PT = Leaf Node / Node / Child Node

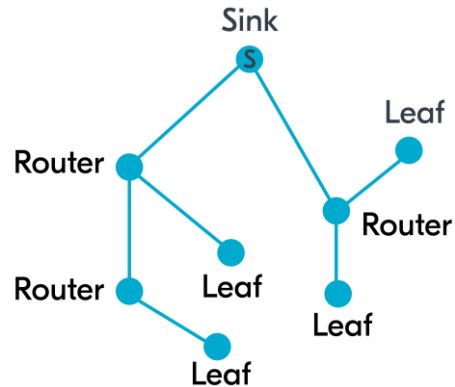

Tree-Mesh

“A mesh network is a local area network topology in which the infrastructure nodes connect directly, dynamically and non-hierarchically to as many other nodes as possible and cooperate with one another to efficiently route data to and from clients.” [Wikipedia](#)

NR+ is a partial mesh, clustered tree topology

Network protocol layers

- Convergence (CVG) layer:
Application multiplexing
- Data Link Control (DLC) layer:
Routing, segmentation
- Medium Access Control (MAC) layer: Radio resource control
- Physical (PHY) layer: OFDM, HARQ, etc.

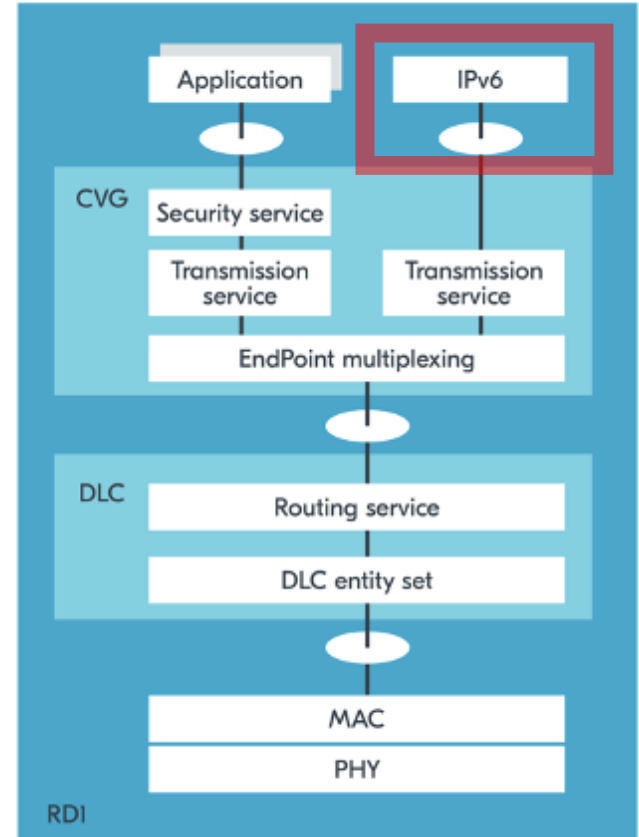

NR+: Convergence (CVG) layer And Data link control (DLC)

- CVG Provides application layer data identification and multiplexing between multiple applications
 - Mesh E2E security
- DLC provides transport service selection
 - 0 Transparent
 - 1 Segmentation
 - 2 ARQ
 - 3 Segmentation and ARQ
- DLC handles routing of packets

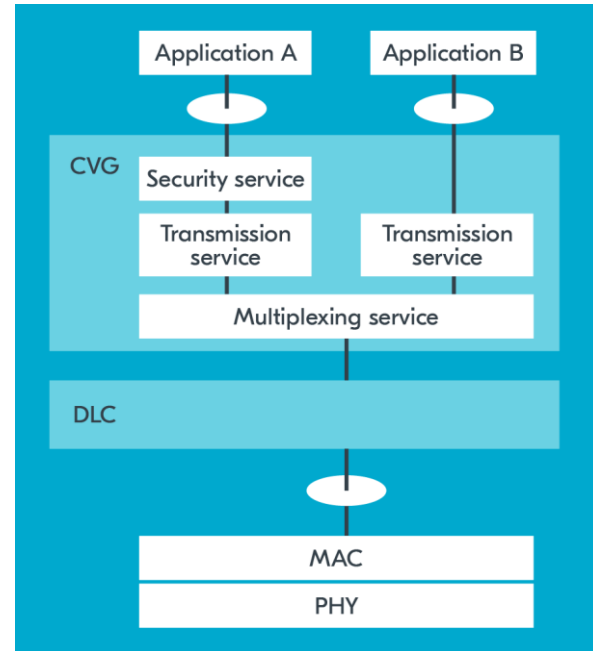

DLC: Network routing

- Up: To sink
 - Forward to parent until it reaches sink
- Sink can forward to internet

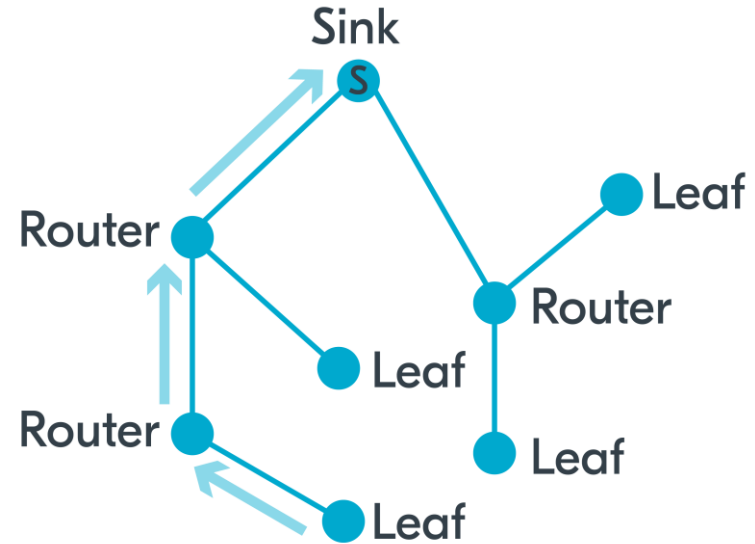

DLC: Network routing

- **Down: Flooding**
 - From sink, forward to all child relays
 - Relays forward to child relays
 - Relay that has the destination as a direct leaf sends only to that leaf
- Flooding with hop limit also for Node-to-Node communication
- Routing is very resilient to changes in network
- Leafs moving to other Relays is instantaneous

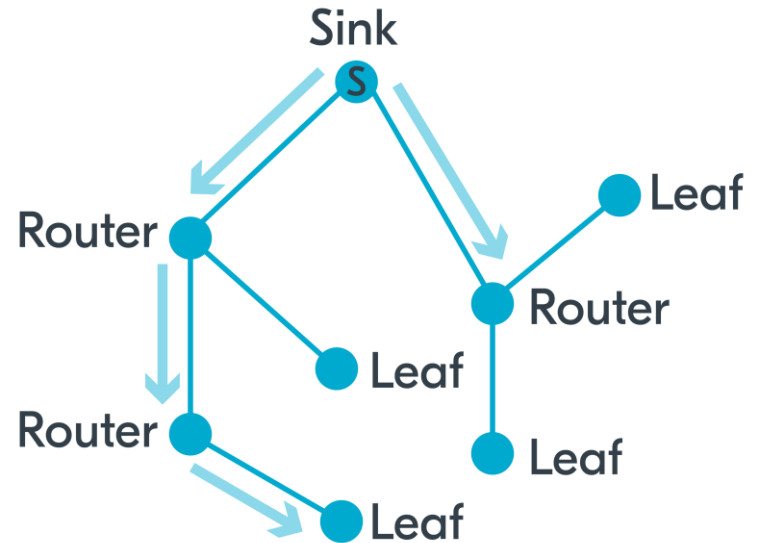

NR+: MAC layer

- Central, lots of features in MAC for the radio resource control
- Broadcast / multicast / unicast
- Dedicated resource or random access
- Radio addresses
 - 32bit network wide address
 - 16bit cluster (link) address
- Beacons for radio resource control
- Hybrid ARQ ACK/NACK to PHY

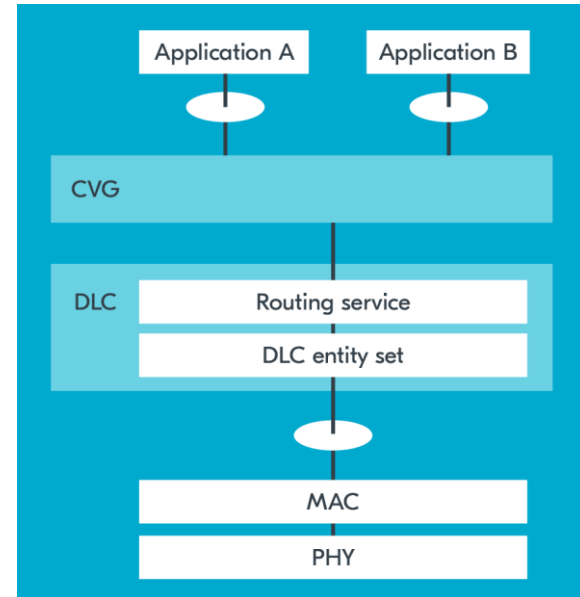

MAC: Radio Channel Resource Control (RRC)



Relay, a routing FT device, manages radio resource with Beacons

- Every beacon period need to scan channel, update reservations for next beacon
- Allocating TX time for leafs in beacons

Leaf follows relay beacon

- Following the beacon avoids dedicated reservations, no scans needed
- Listen before talk on random access channel to relay

RRC: Beacon is the basis

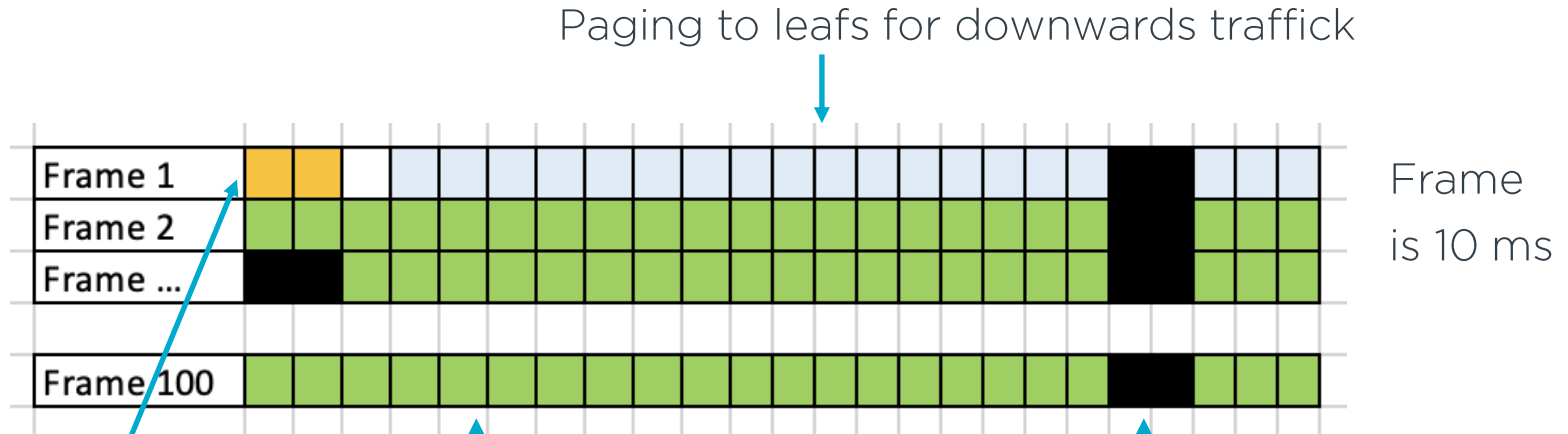

Beacon

Allocated RACH
window for
leaves upwards
traffick

Dedicated flow (or legacy DECT)
detected on scanning the channel
during previous Beacon period

1. Send own
2. Listen parent relay

RRC: Power optimization of beacon

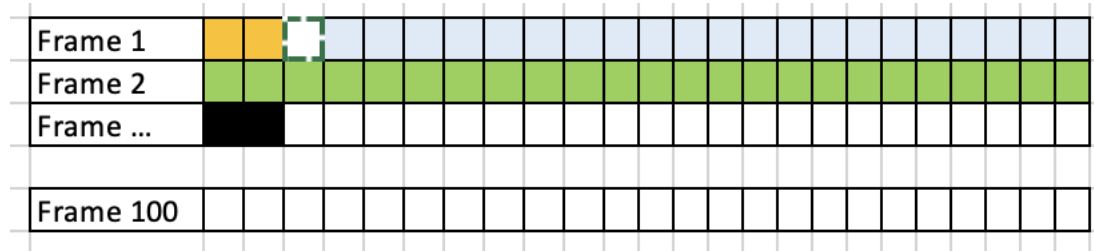

Extreme power save,
low data, long latency

Beacon period can be from 10 ms to 32 secs

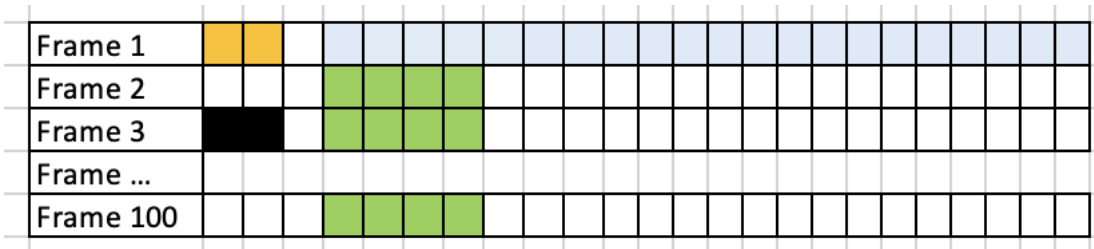

Moderate power save
moderate data, low latency

Summary

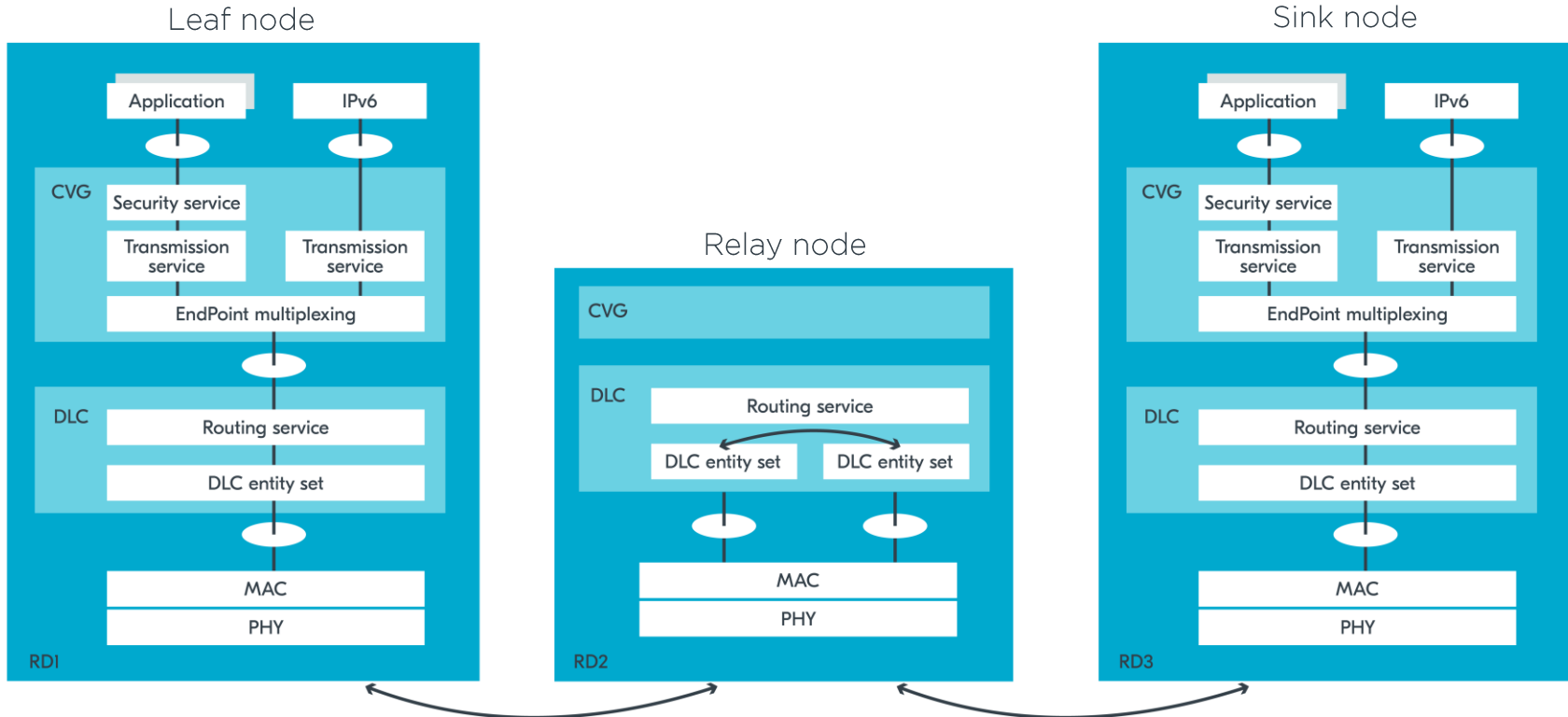

Dedicated flows

- leaf makes an association / modification stating the needed dedicated flow resource
 - How many slots, period, what is the validity period for reservation
- relay verifies the capacity exists and acknowledges
- Dedicated flow slots must be used, the data must be ready for sending at the reserved time
- Dedicated flow is over 1 link only

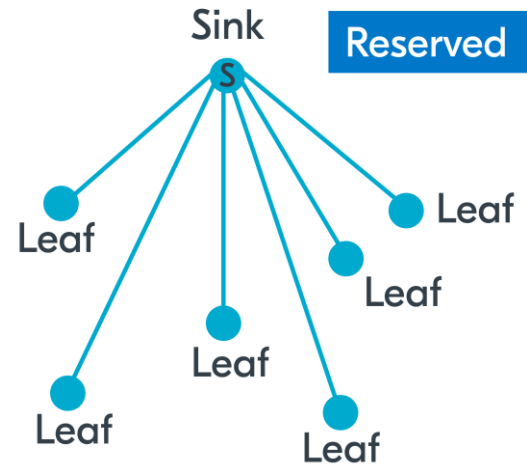



Status of the standard

Standard status

- Core standards are approved by ETSI and ITU, 24 February 2022, now version 1.4.1
 - Overview ETSI TS 103 636-1
 - Radio requirements ETSI TS 103 636-2
 - PHY ETSI TS 103 636-3
 - MAC ETSI TS 103 636-4
 - DLC and CVG ETSI TS 103 636-5
- Working on
 - Harmonized test specification EN 301 406-2
 - Application Profile, Metering TS 103 874
- Gathering requirements for Rel 2 update





Status of the implementation

Status of the implementation, as of April -23

- Nordic will release a DECT NR+ PHY SW Variant for nRF91 series end of 2023
- Our partner in standardization and development Wirepas has a full mesh stack solution on top of the Nordic PHY



WIREPAS 5G MESH

Our Wirepas 5G Mesh will be available later this year. The world's first and only non-cellular 5G connectivity network for enterprise IoT. Connect millions of devices even in the toughest, most demanding environments. Coverage anywhere with a free global dedicated spectrum at 1.9 GHz. Imagine smart meters using 5G without subscription fees and without a slightest coverage issue. Or connected streetlights providing city-wide 5G network for other applications like parking and sewer monitoring. Or an emergency lighting solution that is easy to install and maintain. And it does not stop there. It can do way more. Like a wireless smart building management system that is as reliable as a wired one but for a fraction of the cost. You know cellular can't do this stuff. But we can.

[WATCH VIDEO](#) [GET IN TOUCH](#) [READ MORE ABOUT THE NEW 5G STANDARD](#) [WATCH VIDEO](#)

5G MESH
1.9 GHZ

- For audio and low latency communications Nordic is working with several early access customers

Learn more from Nordic – be self-driven



devzone.nordicsemi.com



academy.nordicsemi.com



webinars.nordicsemi.com

Q&A