

# **ZenduBeacon MS M2**

## **Product Specification**

Version 1.2

# About document

## Scope

This document is applicable to M2 Beacon, and mainly introduced product brief, electronic specifications, quick guidance, and function descriptions based on firmware BXP-D V1.1 series.

## Revision history

Version	Date	Revision history	Author
1.0	2021/06/19	Initial version	Daniel
1.1	2021/06/25	Correct some descriptions	Daniel
1.2	2021/08/06	1. Add 3-axis accelerometer sensor direction descriptions. 2. Modify advertisement parameters descriptions.	Daniel

## Certificates:



\*Please reach out to us if you need any certificates in particular

**M2 Asset Beacon**

The M2, also called Asset Beacon, is an industry-grade Bluetooth LE beacon ideal for enabling asset tracking in harsh and demanding environments. This Beacon also features an Accelerometer sensor and Hall sensor.



Powered by a replaceable CR2477 coin cell battery, M2 Asset Beacon has an outstanding lifetime of over 3 years.



- Rugged IP67 Waterproof
- Temp range -20°C to +60°C
- Industry-grade design



- Replaceable 2477 coin cell battery
- 3 years with motion detection



- Over-the-air updates (firmware)
- Versatile mounting options
- Various configurable parameters



- Up to 160 meters
- Multiple advertising format
- Customized services provided

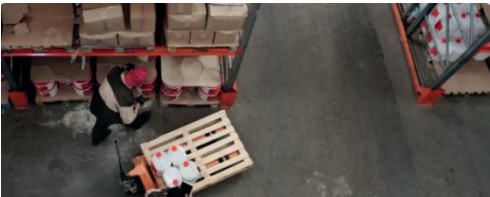

**For What**

- Asset
- Material
- Vehicle
- Machinery
- Equipment



**For Whom**

- Construction
- Manufacturing
- Warehousing
- Healthcare
- Exhibition

## TABLE OF CONTENTS

1. Product Brief.....	4
2. Application Scenarios.....	4
3. Specification.....	5
3.1 General specifications.....	5
3.2 Electronic specifications.....	6
3.2.1 Battery consumption.....	6
3.2.2 Life time.....	7
4. User guidance.....	8
4.1 How to wear/install M2?.....	8
4.2 How to disassemble and assemble M2?.....	9
4.3 How to Power on/off M2?.....	10
4.4 How to restore factory settings?.....	10
4.5 How to connect to APP and issue configurations?.....	11
5. General function.....	11
5.1 Multiple advertising type.....	11
5.2 Multiple advertising slot.....	13
5.3 Motion detection.....	13
5.4 Sensor sampling.....	15
5.5 Magnetic power on/off switch.....	15
5.6 Trigger mechanism.....	15
5.6.1 Button trigger.....	15
5.6.2 Motion trigger.....	16
5.7 Operating mode.....	17
5.7.1 Advertising mode.....	17
5.7.2 Power-off mode.....	17
5.7.3 Connected mode.....	17
5.7.4 Sleep mode.....	18
5.8 Beacon temperature monitoring.....	18
5.9 Monitoring duration statistics.....	18
5.10 Low battery alert.....	18
5.11 Remote power off.....	19
5.12 Remote reboot.....	19
5.13 DFU update.....	19
5.14 Remote parameters configuration.....	19
6. Certifications.....	20
6.1 FCC certification.....	20
6.2 CE regulatory.....	20
7. Ordering information.....	22
7.1 Beacon ordering information.....	22
7.2 Accessory ordering information.....	23
8. Customization services.....	24
9. Service and contact.....	24

## 1. Product Brief

M2 Asset Beacon is mainly used for Assets Tracking, Indoor Navigation, Way-finding, Proximity Marketing etc. With its multiple installation methods and robust enclosure, it can be deployed in factory, warehouse, building and other indoor or outdoor places.



1. Hidden RED LED
2. Magnetic switch
3. Fixing holes

Figure 1: Top view of M2 Beacon



Figure 2: Back view of M2 Beacon

## 2. Application Scenarios

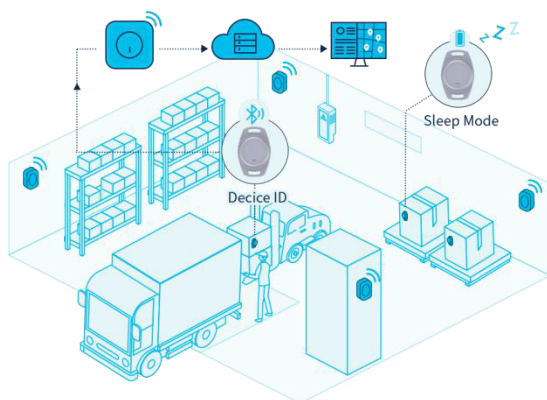

### Scenario 1: Asset tracking

M2 Beacon can be used for theft prevention, vibration detection in forklifts, large-scale asset tracking based on the data sampling of a 3-axis accelerometer sensor.

### Scenario 2: Proximity marketing

M2 Beacon can be installed in exhibition hall or shopping mall, when visitor approaching to a particular product, painting, or shop, then APP will recognize the M2 device info and background server will push relevant info to visitor intelligently.

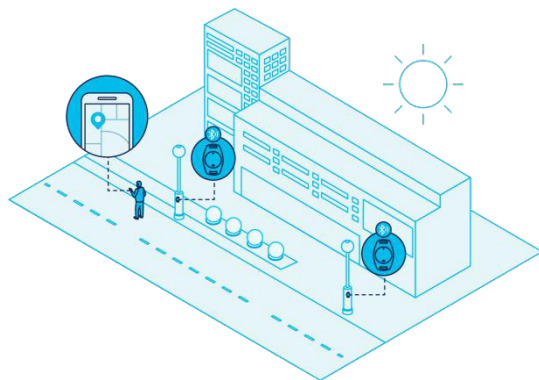
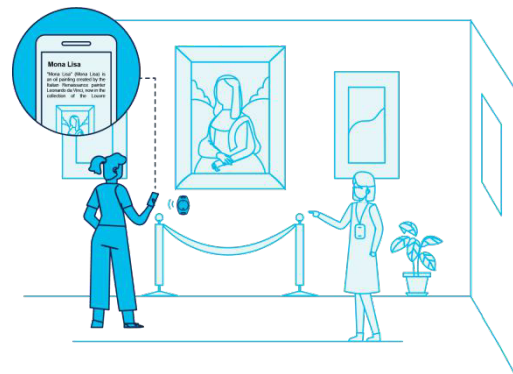

### Scenario 3: Personnel tracking

M2 Beacon can be installed in harsh outdoor environments with its rugged design and outstanding battery life. For instance, it can be installed in streetlamp to be a tag locator. When passengers pass the nearby, it can provide geographical location info.

## 3. Specification

### 3.1 General specifications

General specifications	
Main Chip	Nordic nRF52811
Bluetooth	Bluetooth 4.2(Hardware compatible with Bluetooth 5.1)
Dimension	70mm x 46mm x 21mm
Range	Up to 160 meters (in the open area and no obstacles)
Weight	33.5g (With battery)
Material	ABS+PC
Waterproof	IP67
Color	Gray
Installation	Hang, Sticker, Screw
Button	Mechanical button
LED	Single red LED

General specifications	
Sensor	Omni polar Hall-effect sensor for magnetic switch 3-axis accelerometer sensor (optional)
Operating temperature	General -20°C / + 60°C -40°C / + 85°C can be customized
Storage temperature	-20°C / + 70°C (without battery) 10°C / + 25°C (with battery)
Humidity	0% ~ 95% (non-condensing)
Antenna Type	PCB on-board antenna
Power supply	Replaceable 1000mAh lithium coin CR2477 battery

Table 1: General specifications

## 3.2 Electronic specifications

### 3.2.1 Battery consumption

Here described battery consumption in various situations which refer to different use cases. You can refer to below table to create the use case and estimate battery life time.

3-axis Acc sensor sampling rate	SLOT1			Consumption (uA)	Life time*
	Advertising format	Tx power	Advertising interval		
10H	Device Info	0dBm	100ms	143.3	7.5 months
10Hz	Device Info	0dBm	500ms	40.94	27 months
10Hz	Device Info	0dBm	1000ms	31.22	36 months
10Hz	Device Info	4dBm	100ms	176.84	6.3 months
10Hz	Device Info	4dBm	500ms	46.49	24 months
10Hz	Device Info	4dBm	1000ms	30.83	36 months
10Hz	Device Info	-12dBm	100ms	120.76	9 months
10Hz	Device Info	-12dBm	500ms	35.92	31 months
10Hz	Device Info	-12dBm	1000ms	24.96	45 months
25Hz	Device Info	0dBm	1000ms	33.9	32.6months
100Hz	Device Info	0dBm	1000ms	69.02	16 months

Table 2: Battery consumption in various situations

\* Above battery life time are estimated under continuous single advertising slot with 0dBm Tx power.

### 3.2.2 Life time

Different life time in various typical scenarios.

- Typical scenario 1 - Asset theft prevention.

#### Life time estimation: 3 years

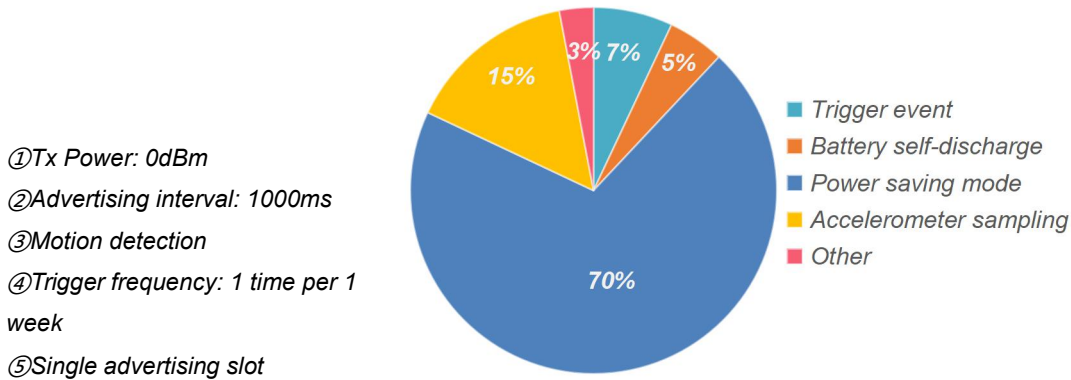

Figure 3: Life time in asset tracking scenario

- Typical scenario 2 - Exhibition promotion.

#### Life time estimation: 4 years

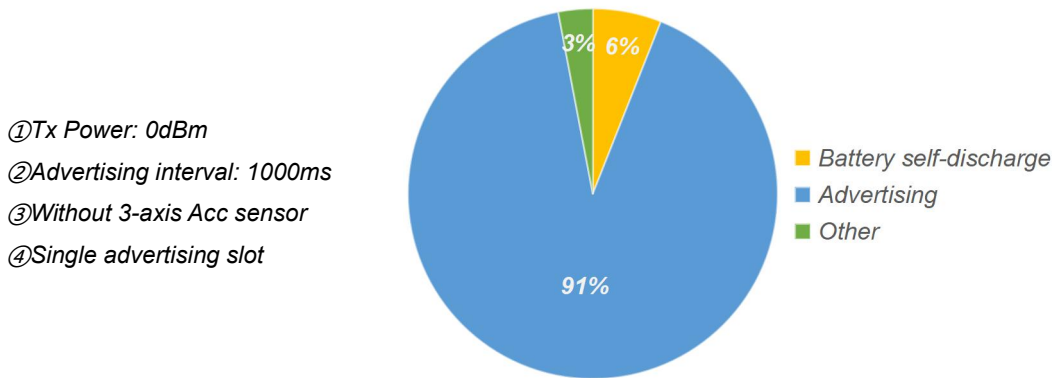

Figure 4: Life time in exhibition promotion scenario

---

Disclaimer: The contents of this battery estimation are for informational purposes only, and while effort has been made to ensure their accuracy, they are not to be construed as warranties or guarantees, express or implied, regarding the products or services described herein or their use or applicability.

---



## 4. User guidance

### 4.1 How to wear/install M2?

Multiple installation options of M2 like hanging with lanyard, screws or double-sided sticker can be selected by user. After deployment, M2 can be easily powered on by a magnet via integrated omni polar Hall-effect sensor and it can avoid accidental control by an external button.

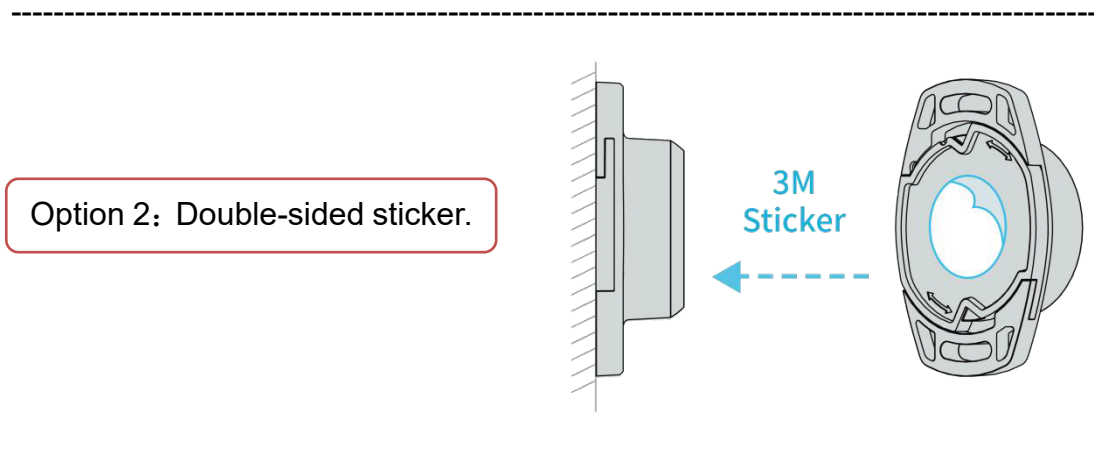
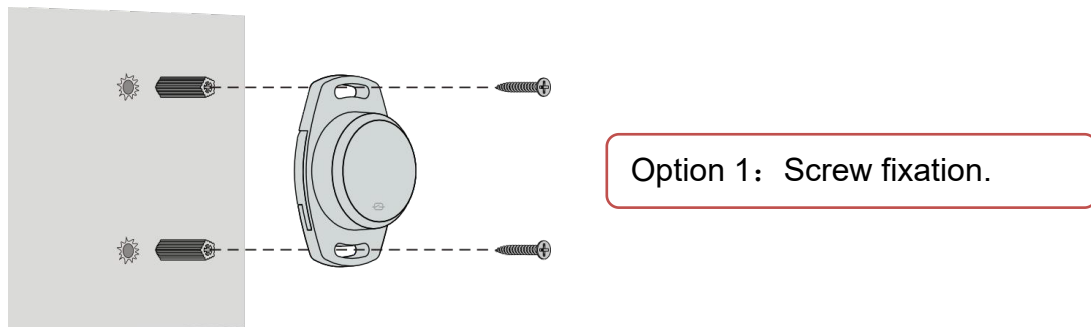

## 4.2 How to disassemble and assemble M2?

Disassemble flow:

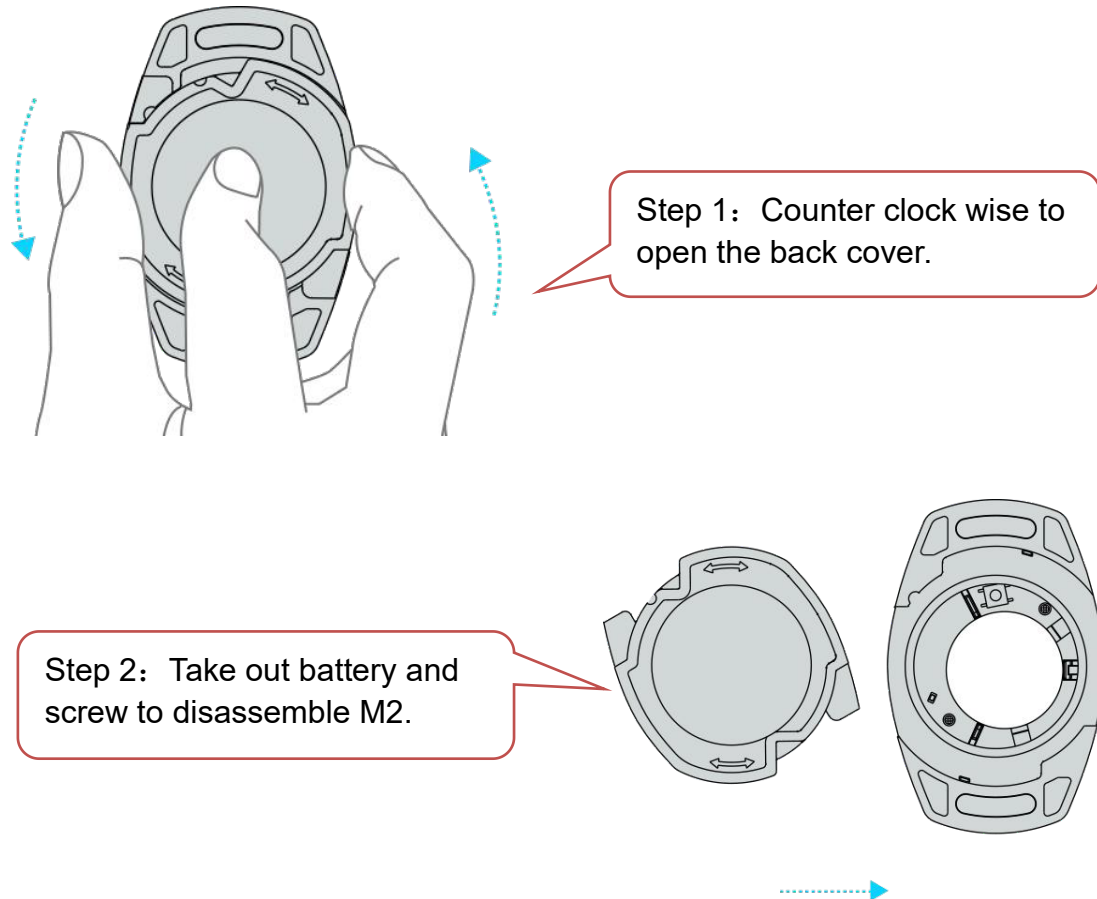

Assemble flow:

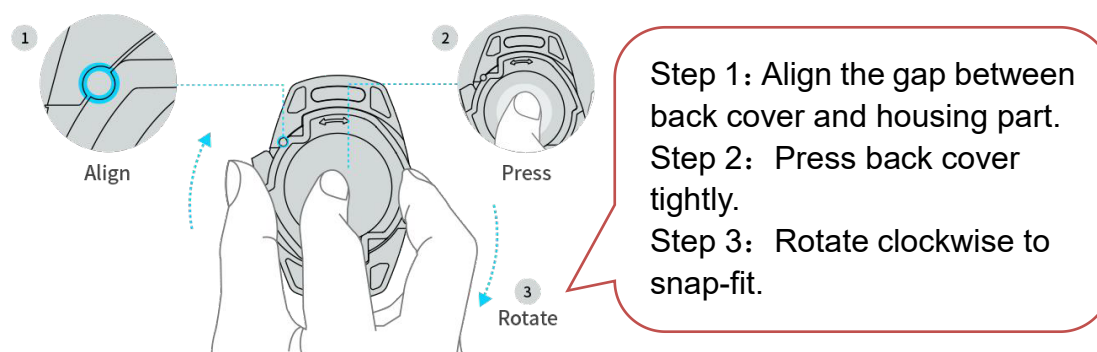

### 4.3 How to Power on/off M2?

There have two ways to power on/off M2.

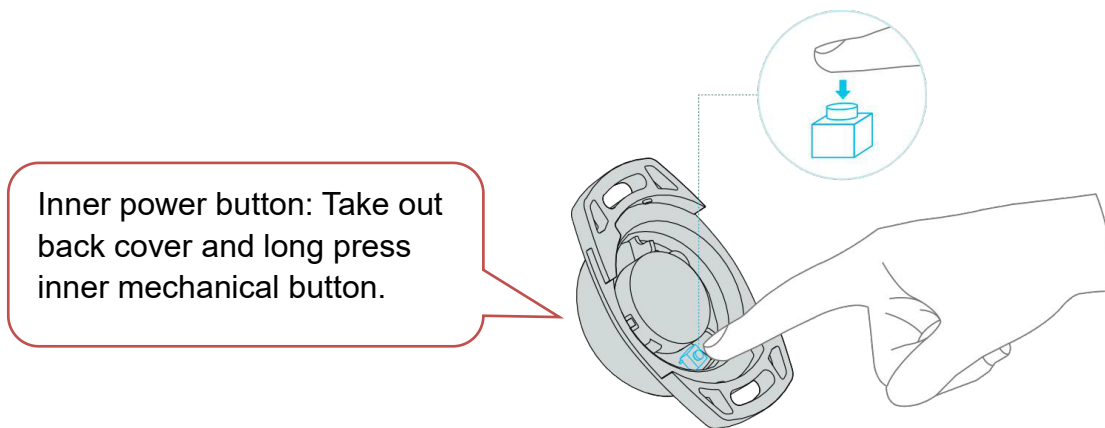
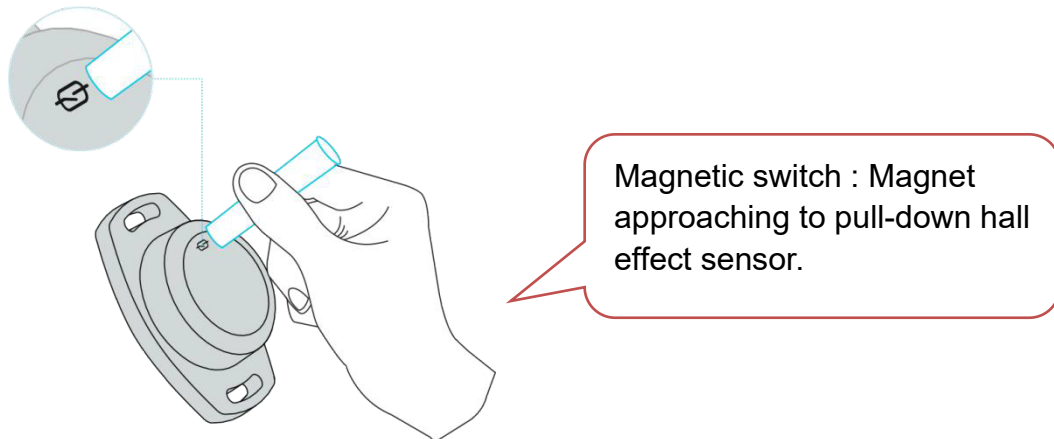

### 4.4 How to restore factory settings?

There have two ways to restore factory settings.

- Inner mechanical button (Hardware reset): In power-off mode, long press inner mechanical button for 10s or more, then release button and single press button within 2s, device will proceed on factory reset.

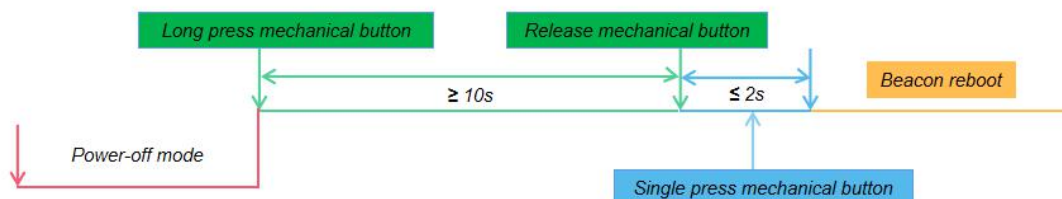

Figure 5: M2 Beacon Factory reset flow

- APP (Software reset\*): Remote factory reset through APP if M2 connected with phone APP.

\* Software reset will not reset connection password.

## 4.5 How to connect to APP and issue configurations?

Please download “BeaconX Pro” APP from play store directly. For more configuration details, please refer to document - “BeaconX Pro series Beacon User Manual”.

## 5. General function

### 5.1 Multiple advertising type

M2 support multiple advertising type to comply with customers' requirements, such as primary Eddystone (UID/URL/TLM) and iBeacon protocol. What's more, M2 also support the MOKO customized protocol to display beacon information and sensor data in real time, thus extending more application scenarios.

#### a) Eddystone-UID

Please refer to below standard Eddystone-UID format:

Byte offset	Field	Description
0	Service UUID	Value = 0xFE AA
2	Frame type	Value = 0x00
3	RSSI@0m	Calibrated Tx power at 0 m
4	Namespace ID	10 bytes Namespace ID
14	Instance ID	6 bytes Instance ID
20	RFU	2 bytes, reserved for future use, must be 0x00

#### b) Eddystone-URL

Please refer to below Eddystone-URL format:

Byte offset	Field	Description
0	Service UUID	Value = 0xFEAA
2	Frame type	Value = 0x10
3	RSSI@0m	Calibrated Tx power at 0 m

4	URL scheme	Encoded Scheme Prefix
5+	Encoded URL	length 1-17

c) Eddystone-TLM (unencrypted)

Please refer to below standard Eddystone-TLM (unencrypted) format:

Byte offset	Field	Description
0	Service UUID	Value = 0xFEAA
2	Frame type	Value = 0x20
3	Version	TLM version, value = 0x00 (unencrypted)
4	Battery voltage	2 bytes; 1mV/bit
6	Beacon temperature	2 bytes
8	ADV_CNT	4 bytes, Advertising PDU count
12	SEC_CNT	4 bytes, Time since power-on or reboot

d) Apple iBeacon

Please refer to below standard APPLE iBeacon format:

Byte offset	Field	Description
0	Company ID	Value = 0x4C 00 (Apple, Inc.)
2	iBeacon type	Value = 0x02 (Proximity Beacon)
3	iBeacon length	Value = 0x15 (Fixed)
4	UUID	16 bytes
20	Major	2 bytes
22	Minor	2 bytes
24	RSSI@1m	1 byte, Calibrated Tx power at 1 m; Range: -100~0dBm

e) 3-axis Acc sensor

MOKO customized advertising format for broadcasting 3-axis sensor raw data, battery voltage etc. Please refer to below table for details.

Byte offset	Field	Description
0	Service UUID	Value = 0xFEAB
2	Frame type	Value = 0x60
3	Ranging data	1 byte, the Tx power in dBm emitted by the Beacon at custom distance (0m or 1m) Range: -100~0dBm
4	Advertising interval	1 byte, 100ms/bit; Range: 1~100
5	Sensor sampling rate	1 byte, 25Hz by default
6	Sensor full-scale	1 byte, ±2g by default
7	Trigger threshold	1 byte, the acceleration value to determine Beacon motion, 0.1g by default
8	Sensor data	6 bytes, the acceleration of X-axis, Y-axis, and Z-axis

14	Tx power	3 bytes (Tx power)
17	Battery voltage	2 bytes; 1mV/bit
19	RFU	1 byte, reserved for future use
20	MAC address	6 bytes

#### f) Device info

MOKO customized advertising format for broadcasting device status info.

Please refer to below table for details.

Byte offset	Field	Description
0	Service UUID	Value = 0xFEAB
2	Frame Type	Value = 0x40
3	Ranging data	1 byte, the Tx power in dBm emitted by the Beacon at custom distance (0m or 1m) Range: -100~0dBm
4	Advertising interval	1 byte, 100ms/bit; Range: 1~100
5	Battery voltage	2 bytes, 1mV/bit
7	Device property	Bit0-1, 00–need password; 11-no password is required.
		Bit2-7, reserved for future use
8	Device property	Bit0, 0-Unconnectable; 1-Connectable
		Bit1-7, reserved for future use
9	MAC Address	6 bytes
15	Software version	2 bytes
17	Tx power	1 byte

In this customized device info frame, there have corresponding response package which contains device name. (Need enable active scanning)

Byte offset	Field	Description
0	Device name	Maximum 22 bytes 20 characters and 2 bytes type & length

## 5.2 Multiple advertising slot

M2 can support up to 6 advertising slots and each slot configurations are independent. It means that user can issue different configurations which include Tx power/ Adv interval/ Adv type and other parameters in each slot.

## 5.3 Motion detection

3-axis accelerometer sensor could be able to identify M2 motion status, and

then switch into pre-configured advertising status or data. As well, user can also set motion detection trigger to achieve power saving mode. For more, please refer to "[chapter 5.6.2 motion trigger](#)".

Use case: Install M2 Beacon in the valuable asset and set motion trigger - Stop broadcasting for a specific period (30s default). When asset in idle status for more than 30s, M2 will be in power saving mode and stop broadcasting. Once asset moved and 3-axis sensor sampling value exceed to threshold value, then motion detection will be triggered and M2 will start broadcasting, thus indicating the alarm and reminder.

Regarding to 3-axis accelerometer sensor directions, you can refer to below hardware design and sensor specifications.

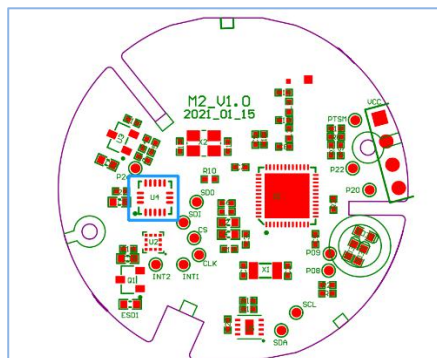

Figure 6: M2 Beacon PCBA design

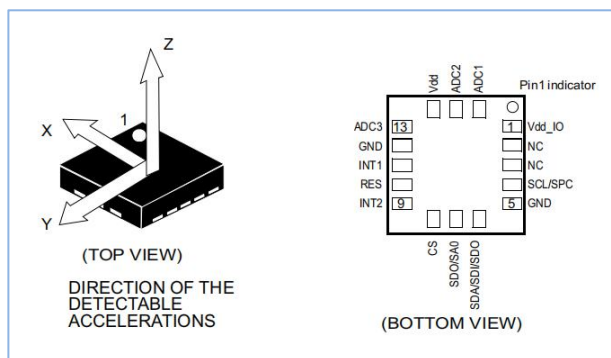

Figure 7: 3-axis accelerometer sensor specification

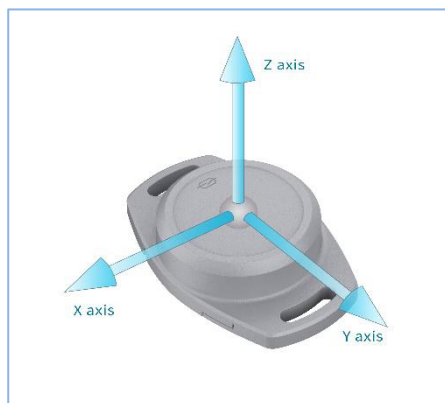

Figure 8: M2 accelerometer sensing direction

For M2 Beacon sensing direction with 3-axis accelerometer sensor, please refer to figure 8.

## 5.4 Sensor sampling

M2 can broadcast or notify 3-axis sensor data in real time, so you can achieve the sensor sampling data through advertisement or Connection Notify property. It could be used for personnel tracking and behavior surveillance.

## 5.5 Magnetic power on/off switch

M2 have adopted omni polar Hall-effect sensor, when magnet approaching, it will pull-down hall effect sensor to achieve power on/off switch.

## 5.6 Trigger mechanism

Trigger mechanism is designed for some emergency states switching immediately or some specific use cases such as motion detection. Currently M2 Beacon can support mechanical button trigger and motion trigger, please refer to below trigger table.

Trigger type	Trigger condition
Button trigger	Press button twice
	Press button three times
Motion trigger	Device moves

User can set the different trigger type, as well as trigger response. When the trigger condition takes effect, then it will have corresponding trigger response.

For instance, user set the trigger type - motion trigger, and set the trigger response - stop advertising for a while (30s). When device is in idle status, if user move device and then 3-axis sensor data exceed to threshold value (motion detected), then it will activate trigger response and device will stop advertising for 30s.

### 5.6.1 Button trigger

- Description

There have two kinds of trigger conditions regarding of button trigger, that is double click button and triple-click button.



- Trigger response

- a) Always advertising

After trigger type being occurred, then device will start broadcasting and keep always broadcasting until you change to other trigger response or cancel trigger type.

- b) Start advertising for a while

After trigger type being occurred, then device will start advertising for a while, and advertising time is configurable. It is set 30s by default.

- c) Stop advertising for a while

After trigger type being occurred, then device will stop advertising for a while, and advertising time is configurable. It is set 30s by default.

- Use cases

- a) SOS emergency & call services

- b) Regular task report

## 5.6.2 Motion trigger

- Description

When device changed from idle to motion status, 3-axis sensor sampling data exceed to threshold value, it will be recognized as an effective motion and then activate trigger response.

- Trigger response

- a) Always advertising

After trigger type being occurred, device will start advertising and keep always advertising until you change to other trigger response or cancel trigger type.

- b) Start advertising after a static period of specific time

Device will start to broadcast after a static period of specific time and it stops broadcasting again once a movement occurred. It is set 30s by default.

- c) Stop advertising after a static period of specific time

Device will stop broadcasting after a static period of specific time and it starts to broadcast again once a movement occurred. It is set 30s by default.

- Use cases

- a) Power saving mode & Normal mode switch

- b) Asset status monitoring

## 5.7 Operating mode

Regarding of M2 Beacon, there have several operating modes which reflect on different features and states. Please refer to below operating mode flow.

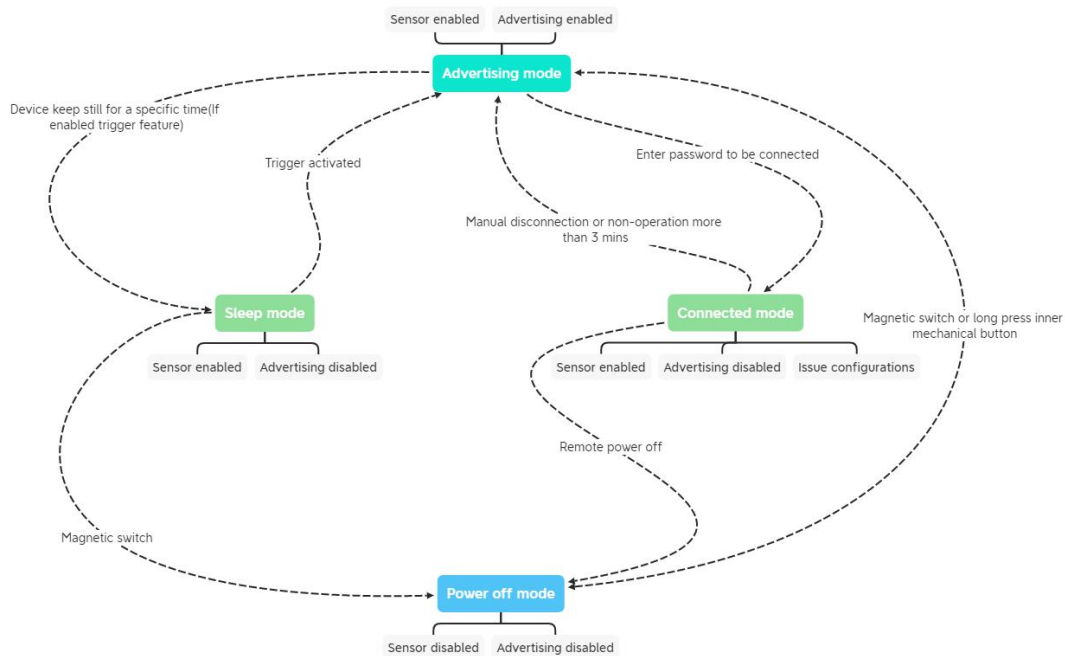

Figure 9: M2 Beacon Operating mode flow

### 5.7.1 Advertising mode

In advertising mode, M2 Beacon is broadcasting, sensor is working and can be scanned by central device.

### 5.7.2 Power-off mode

MCU will enter low power mode to wait for power on event, beyond that, all services which include advertisement, sensor, RTC etc. will be disabled.

### 5.7.3 Connected mode

In this mode, central device (phone, gateway, or other master devices) is connected with M2 Beacon and can configure parameters through GATT services.

When a connection is made to M2, the part will stay in a connected state until the master breaks the connection or is out of range. On disconnect, M2 returns to the broadcasting state unless a reset was initiated during the connection.

In connected mode, M2 Beacon will not broadcast but sensor is working still.

#### 5.7.4 Sleep mode

In sleep mode, M2 is not connected with central device and not broadcasting as well, but sensor is working to wait for motion trigger or button trigger. For instance, after device keep in idle status for a specific time (default 30s and parameters configurable), then device will stop broadcasting but keep sensor sampling working to maintain motion detection feature, that is called power saving mode.

### 5.8 Beacon temperature monitoring

In M2 Beacon, nRF52811 equipped with a built-in temperature sensor and temperature data will be broadcast through TLM frame. User can monitor the beacon temperature and do forewarning measures.

### 5.9 Monitoring duration statistics

In TLM frame, there have a SEC\_CNT value that represents time since beacon power-up or reboot. User can do monitoring duration statistics through this value.

Use case - Products promotion

When customer pick up specific goods, motion detection in M2 beacon will be triggered. The merchant can calculate the trigger frequency by combining the motion trigger times and total monitoring duration, thus providing the customer preference analysis.

### 5.10 Low battery alert

When battery percentage is lower than 5%, LED blinks twice at 10s interval to remind user.

---

*\* Low battery alert threshold can be customized regarding of customer requirements.*

---

## 5.11 Remote power off

Device firmware can support remote power off feature. This function should be realized through APP.

## 5.12 Remote reboot

Device firmware can support remote reboot feature. This function should be realized through APP.

## 5.13 DFU update

Device support DFU firmware update, and you can do DFU operations through official “nRF Connect” APP or Moko “BeaconX Pro” APP.

During firmware update period, LED will keep red blinking; After successful update, LED will keep red solid for 2s and then device reboot. For more detail instructions, you can refer to document - “BeaconX Pro series Beacon User Manual”.

## 5.14 Remote parameters configuration

Device support various configurable parameters and you can issue below parameters through “BeaconX Pro” APP directly.

- Advertising format and data
- Advertising slot
- Beacon name
- Tx power
- Advertising interval
- Connection password
- Trigger options
- Sensor parameters

## 6. Certifications

### 6.1 FCC certification

#### **FCC Interference Statement**

This equipment has been tested and found to comply with the limits for a Class B digital device, pursuant to Part 15 of the FCC Rules. These limits are designed to provide reasonable protection against harmful interference in a residential installation. This equipment generates, uses, and can radiate radio frequency energy and, if not installed and used in accordance with the instructions, may cause harmful interference to radio communications. However, there is no guarantee that interference will not occur in an installation. If this equipment does cause harmful interference to radio or television reception, which can be determined by turning the equipment off and on, the user is encouraged to correct the interference by one or more of the following measures:

- Re-orient or relocate the receiving antenna.
- Increase the separation between the equipment and the receiver.
- Connect the equipment into an outlet on a circuit different from that to which the receiver is connected.
- Consult the dealer or an experienced radio/TV technician for help.

#### **OEM Responsibilities**

**WARNING:** Changes or modifications not expressly approved by Laird could void the use's authority to operate the equipment.

#### **FCC Warning**

This device complies with part 15 of the FCC rules operation is subject to the following two conditions: (1) this device may not cause harmful interference, and (2) this device must accept any interference received, including interference that may cause undesired operation.

### 6.2 CE regulatory

#### **CE-RED**

Manufacturer	MOKO TECHNOLOGY LTD.
Product	M2
Product Description	IP67, industry-grade Asset Beacon
EU Directives	2014/53/EU - Radio Equipment Directive (RED)

Reference standards used for presumption of conformity:

Article number	Requirement	Reference standard(s)
3.1(a)	Health & Safety	EN 62311:2008 EN 50665:2017 EN 50385:2017 EN 62368-1:2014
3.1(b)	Protection requirements – EMC compatibility	EN 301 489-1 V2.2.0 (2017-03) EN 301 489-17 V3.2.0(2017-03)
3.2	Means of the efficient use of the radio frequency spectrum (ERM)	EN 300 328 V2.1.1 (2016-11)

## RoHS

All products that are manufactured by MOKO TECHNOLOGY LTD. follow the Directive 2011/65/EU of the European Parliament & of the Council & Commission Delegated Directive (EU) 2015/863, on the restriction of the use of certain hazardous substances in electrical and electronic equipment.

## REACH

Two hundred and eleven (211) substances in the Candidate List of Substances of Very High Concern (SVHC) for authorization published by European Chemicals Agency (ECHA) on - (EC) No 1907/2006 concerning the REACH. we confirm that:

1. None of our products are intended to release any hazardous chemicals.
2. We have or will contact suppliers who supply us with substances that may likely require registration under REACH regulations to request confirmation that the chemicals of concerns were either registered or they have requested their downstream suppliers to do so.
3. We will take appropriate action in response to any to business risks arising through supplier failure to co-operate and support us in this project.
4. We will do our utmost to ensure that continuity of supply of our products will not be adversely affected by issues arising from the REACH regulations.

## 7. Ordering information

### 7.1 Beacon ordering information

The M2 Beacon is available as a finished product in a plastic housing with full FCC, RoHS, REACH and CE certification.

The M2 Beacon ordering information is shown in Figure 10 and Table 3.

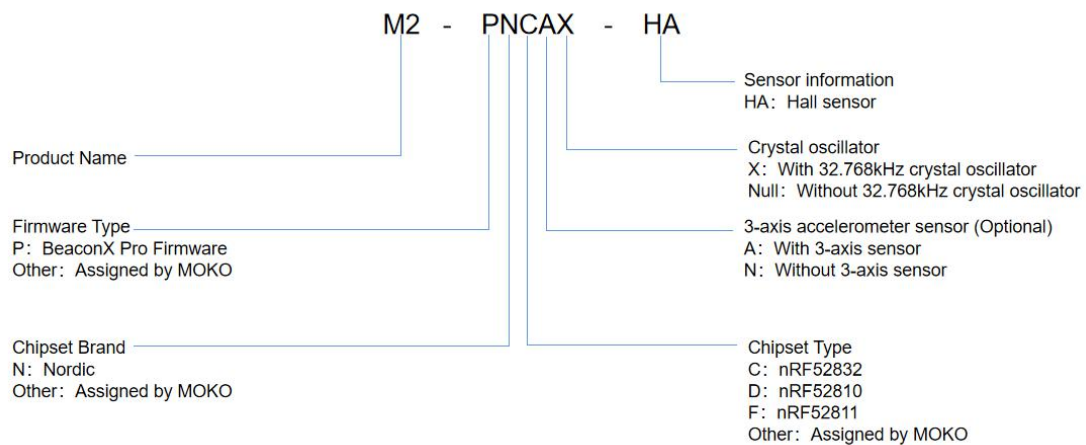

Figure 10: M2 Beacon Ordering Information

Order number	Description			
	Chipset	3-axis Acc sensor	Hall sensor	Clock oscillator
M2-PNFA-HA	nRF52811	√	√	○
M2-PNFN-HA	nRF52811	○	√	○
M2-PNCAX-HA	nRF52832	√	√	√
M2-PNDA-HA	nRF52810	√	√	○
M2-PNDN-HA	nRF52810	○	√	○

Table 3: M2 Beacon Ordering Information

## 7.2 Accessory ordering information

The Magnet is also available for custom ordering as an additional accessory. And below is the ordering information for accessory magnet:

Order number	Description
12310000300379	Beacon Magnet, Type 5C-35
12310000300380	Beacon Magnet, Type 5C-36

Table 4: Beacon Magnet Ordering Information



Beacon Magnet Specifications		
Parameters Type	5C-35	5C-36
Appearance		
Dimension	Refer to Figure 8	Refer to Figure 9
Detection distance	$\geq 20\text{mm}$	$\geq 30\text{mm}$
Operating temperature	$-20^{\circ}\text{C} \sim 80^{\circ}\text{C}$	$-20^{\circ}\text{C} \sim 80^{\circ}\text{C}$
Switch Lifetime	$> 100000$ times	$> 100000$ times
Material	ABS	ABS
Color	White/Brown	White/Brown
Certification	CCC/CE/FCC/RoHS	CCC/CE/FCC/RoHS

Table 5: Beacon Magnet Specifications

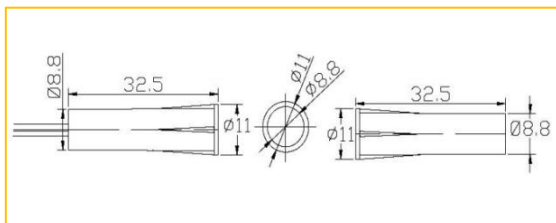

Figure 11: Magnet 5C-35 Dimensions

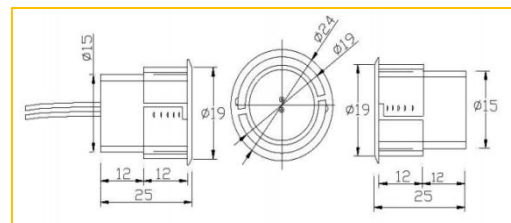

Figure 12: Magnet 5C-36 Dimensions



## 8. Customization services

To realize all-round marketing services, MOKO can provide below customization services:

- a) Firmware
- b) Hardware design
- c) Laser logo
- d) Packaging
- e) Label
- f) Certifications

For more customization services, please contact with MOKO sales team.

## 9. Service and contact

"Please contact [support@zenduit.com](mailto:support@zenduit.com) for any further clarifications regarding setup and specifications."