



Product Specification for Li-ion Polymer Battery

Model : LD403533

Prepared by/Date	Checked by/Date	Approved by
Jack 2022-10-26	Bob 2022-10-26	Rapport 2022-10-26

Customer Name	
Customer No	
<p>Note: 1. Please kindly sign on the underneath and send it back to us if the samples have been approved. 2. If the sample didn't pass the customer's test, please contact us as soon as possible. Thank !</p>	
Client Confirmation	
STAMP	



1. Scope :

This document describes the Product Specification of the Li-Polymer Rechargeable Battery supplied by Huizhou Leader New Energy Co., Ltd.

2. Description

2.1 Description: Li-Polymer Battery

2.2 Model:LD403533

3. Specification

3.1 Basic Performance

No.	Item	Spec		Note
1	Nominal Capacity	450mAh	0.2C Discharge	0.2Crate,3.0V cut-off
	Minimum Capacity	435mAh		
2	Nominal Voltage	3.85V		
3	MAX Charge Voltage	4.4V		
4	DischargeCut-Off Voltage	3.0 V		
5	Charge current	Standard charge: 0.2C Rapid charge: 1C		
6	Standard charging	0.2C CC (constant current) charge to 4.4V, then 4.4V CV(constant voltage) charge till charge current decline to \leq 0.02C		
7	Discharge Current	Standard Discharge: 0.2C Max Discharge:1C		
8	Storage temperature	1 month : -10~45°C 6 month : -10~35°C 20±5 °C is recommend long term storage temperature		
9	Weight	Approx: :7g		
10	Operating temperature	Charging : 0~+45 °C , Humidity \leq 85%RH Discharge : -20~+60 °C , Humidity \leq 85%RH		<0°C Charge shall be prohibited



11	Cell Voltage	3.95 ~4.1V	As of shipment
----	--------------	------------	----------------

4. Battery Cell Performance Criteria

4.1 Standard testing environment

Unless specifically stated otherwise, tests must be done within one month of delivery and the number of charging-recharging cycles is fewer than 5. The following is test conditions:

Test conditions:

Ambient Temperature: $23^{\circ}\text{C} \pm 2^{\circ}\text{C}$

Ambient Humidity: $65 \pm 20\% \text{RH}$

4.2 Electrical Characteristics

NO	Item	Test Method	Criterion
1	Visual inspection	visual inspection	Not allowing any visual defects which will affect the electronic characteristics, such as leakage and damage.
2	Battery Dimension	Digital Calipers	Length 长度: MAX35mm Width 宽度: MAX35mm Thickness 厚度: MAX40mm
3	Initial Impedance	Internal resistance measured at AC 1KHz after 50-60% charge	Battery $\leq 100\text{m}\Omega$
4	Rated Capacity	The capacity means the discharge capacity of the cell, which is measured with discharge current of 0.2C with 3.0V cut-off voltage after the standard charge.	$\geq 435\text{mAh}$



5	Cycle Life	Test condition: Charge: 0.2C to 4.4V Discharge: 0.2C to 3.0V When the discharge capacity reduced to 70% of rated capacity, Stop testing	The cycle times is not less than 300
6	High Temperature	A charged battery is placed in an oven for 2 hours at 55°C±2°C, then discharged at a 0.2C current to the termination voltage.	Discharge 80 percent of the original capacity.
7	Low Temperature	A charged battery is placed in a thermal chamber for 4 hours at - 10°C±2°C; then discharged at 0.2C to the termination voltage.	Discharge 70 percent of the original capacity.
8	Electricity maintenance	After the standard charging, storied the cells under the condition as 20± 5 °C for 30days, then measured the capacity with 0.2C till 3.0V	Remaining capacity ≥ 80%

4.3 Environment Characteristics

NO	Item	Test Method	Criterion
1	Constant temperature and constant humidity test	After Standard Charging, test condition: Temperature: 40±2°C Relative Humidity: 90~95%RH Storage Time: 48 hours Then return to room temperature for 2 hours , Then 1C discharged to ending voltage	No explosion , no fire , no leakage. Discharging capacity is not less than 60% original capacity



2	Vibration test	After Standard Charging, fixed the cell to vibration table, then subjected to vibration test for 30 minutes per axis of XYZ axes. Frequency rate : 1 oct/min Vibration frequency : 10Hz-30Hz Excursion(single amplitude): 0.38mm Vibration frequency : 30Hz-55Hz Excursion(single amplitude): 0.19mm	No explosion, no fire , no leakage
3	Drop Test	A charged battery is dropped from a height of 1 meter two times onto a concrete surface.	No explosion, no fire, no leakage.

4.4 Safety Characteristics

NO	Item	Method	Criterion Test
1	Overcharge test	Discharge : 1C to 3.0V Charge : 3C to 4.6V Stop the test when the surface temperature of the cell decays to about 20% from the maximum or continuous charging time up to 7 hours.	No explosion, no fire
2	Short-circuit test	After Standard Charging , Short circuit the positive and negative , and the resistance of copper wire is not more than 80mΩ , Stop the test when the surface temperature of the cell decays to about 20%from the maximum or short time reaches 24 hours.	No explosion, no fire
3	Thermal test	Put cell into an hot box, test condition: Temperature Rate : 5 ± 2 /min °C Ending temperature : 130 ± 2 °C Keep temperature for 30 minutes , Then stop testing.	No explosion, no fire



Note: Above testing of safe characteristics must be with protective equipment.

5. Storage and others

5.1 Longterm Storage

If the cell is to be stored for 3 months or longer it should be held in a dry and cool environment. Voltage during storage needs to be maintained between 3.6V~3.9V and the storage conditions are the same as $20 \pm 5^\circ\text{C}$.

$20 \pm 5^\circ\text{C}$ 5.2 Any issues not covered in this specification should be discussed between the customer and

Constant Li.

6. Warranty

Warranty period for this product is 6 months starting from the date that the batteries are shipped out from Constant Li factory (the printing date on the cell).

7. Drawing

7.1 Assembly diagram (not to scale)

Model: LD403533

Unit: mm

Cell size

区域	W	H	T	A	A1	H1
规格尺寸	≤ 35	≤ 33	≤ 40	≤ 7	≤ 1.5	≤ 3

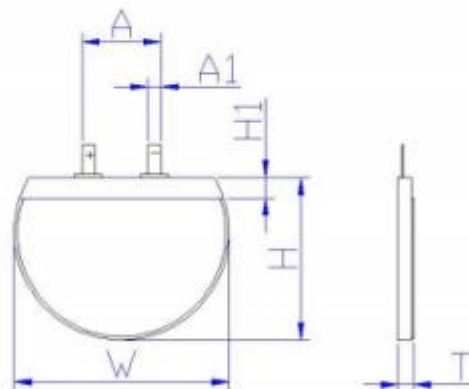



8 、 Warnings and cautions

Warning :Danger warning (it should be described in manual or instruction for users, indicated especially) to prevent the possibility of the battery from leaking, heating, explosion. Please observe the following precautions:

Do not disassemble or modify the battery.

Keep the battery away from children.

Do not touch a leaked battery directly.

Do not use the battery with defect such as conspicuous damage or deformation.

Do not reverse the positive (+) and negative (-) terminals.

When recharging, use the battery charger specifically for that purpose.

Do not use or leave the battery near a heat source such as fire or heater.

Do not short-circuit the battery by directly connecting the positive (+) and negative (-) terminals with metal objects such as wire.

Do not transport or store the battery with metal objects such as necklaces, hairpins etc.

Do not strike or throw the battery against hard surface.

Do not directly solder the battery and pierce the battery with a nail or other sharp object.

Do not immerse the battery in water or seawater, and keep the battery in a cool dry environment during stands by period.

Do not connect the battery to an electrical outlet.

Do not dispose the battery in fire or heat.

Do not use lithium ion battery and others different lithium polymer battery model in mixture

Prohibition of use of damaged cells.

Don't bend or fold sealing edge. Don't open or deform folding edge Don't fillet the end of the folding edge.

Battery pack designing and packing Prohibition injury batteries.

Cautions

Please read the specific charger manual before usage.

We suggest that using point welding to connect electrode and PCB is well, soldering or other welding method with long time heating electrode can make the battery leakage or sealing failure.

Unless otherwise specified, the standard test temperature of the battery should be 23 ± 2 °C .

In case of long time storage (more than 3 months), the battery should be in a low humidity ,no corrosive gas area and at 20 ± 5 °C at half charged stage.



Charge the battery at operating temperature range of 0~45°C ,the cycle life of the battery will be shortened when charged at low temperatures.

Discharge the battery at operating temperature range of - 10 ~ 60°C .

Do not use or leave the battery at very high temperature (for example, at strong direct sunlight or in a vehicle in extremely hot weather).Otherwise, it can overheat or fire or its performance will be degenerate and its service life will be shortened.

Do not use the battery in a location where static electricity is rich, otherwise, the safety devices may be damaged, causing a harmful situation.

In case the electrolyte get into the eyes due to the leakage of battery ,do not rub the eyes, rinse the eyes with clean running water, and seek medical attention immediately .Otherwise, it may injure eyes or cause a loss of sight.

If the battery gives off an odor, generates heat, becomes discolored or deformed, or in any way appear abnormal during use ,recharging or storage ,immediately remove it from the device or battery charger and place it in a contained vessel such as a metal box.

9. Special Notice :

9. 1 If the cell isn't used for a long time, please keep the cells in a half-charged state neither fully charged and not completely discharged. Recharge the cells and use half of the power after 2-3 months. Store the cells in a cool and dry place. It will protect the cell from damage.

9.2 Any components contacting these two edges, they must be insulated.

10. Liability

The user has to operate the products according to the instructions printed on the battery label or follow the advices described in this "Lithium-ion Rechargeable Battery Specification" published by Leader. In case the battery were overheated or even catch fire or explosion caused by mishandling of the user side, Leader will not be liable for the lose caused by any of such mishandling. The customer is requested to contact Constant Li in advance if and when the customer needs variations of the operating conditions described in this document. Additional experimentation may be required to verify performance and safety under such conditions.